

- Practical adjustment with rotating mechanical support plates.
- End milling of 1 to 6 profiles.
- Easy and safe cutter change as it is pneumatical and has special lock system.

- Front sections to store the cutters.

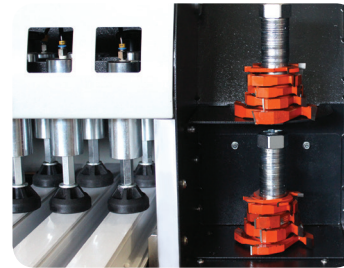

- Side press pistons to provide end milling at setsquare.
- End milling of 6 profiles at the same time.
- Thanks to screwed shaft system the speed is adjusted electronically to provide high quality products.

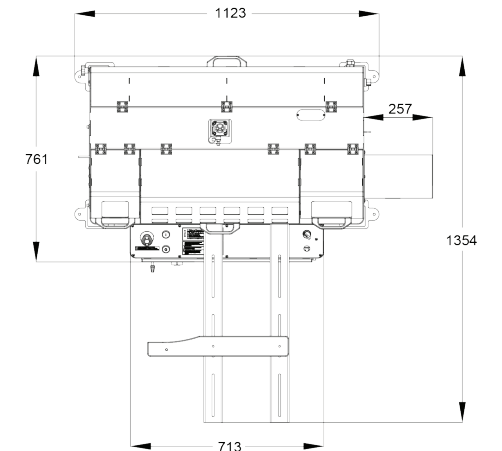

General Features

- End milling of PVC profiles.
- Practical cutter progress speed adjustment thanks to screwed shaft system.
- Safe operation with safety cover.
- Electronical speed adjustment prevents profiles breakage while processing.
- Support arms in front of the machine to provide stable end milling of profiles up to 2.5 meters.

Optional Equipments



- End Milling Cutters

<p>H: 1860 mm W: 1320 mm L: 1410 mm</p>	<p>400 V L1-L2-L3-N-PE 50 / 60 Hz 2.05 kW</p>	<p>340 kg</p>	<p>6-8 Bar 380 l / min</p>	<p>a [min:25mm h max:120 mm min:25mm</p>	<p>ØD: 210 mm Ød: 30 mm h max: 130 mm</p>
---	---	---------------	--------------------------------	--	---